

Compression force transducer up to 100 kN

with electrical output



Description

Because of its small dimensions and solid design this load cell made of high grade stainless steel can be used in the laboratory and testing sector in the most diverse branches of industry.

This load cell is easy to handle and is relatively easy to install.

Due to its small dimensions it is predestined for installation more especially in structures where space is at a premium and pressure forces have to be measured.

Note

In order to avoid overloading, it is advantageous to connect the load cell electrically during installation and to monitor the measured value.

The force to be measured must be applied concentrically and free of transverse force.

The load cells are to be mounted on a level surface.

| Ordering code | |
|---------------|--------------|
| (kN) | Order No. |
| 0 ... 0.01 | 3097.100.430 |
| 0 ... 0.02 | 3097.100.431 |
| 0 ... 0.05 | 3097.100.432 |
| 0 ... 0.1 | 3097.100.433 |
| 0 ... 0.2 | 3097.100.434 |
| 0 ... 0.5 | 3097.100.435 |
| 0 ... 1 | 3097.100.436 |
| 0 ... 2 | 3097.100.437 |
| 0 ... 5 | 3097.100.438 |
| 0 ... 10 | 3097.100.439 |
| 0 ... 20 | 3097.100.440 |
| 0 ... 50 | 3097.100.441 |
| 0 ... 100 | 3097.100.442 |

Features

- for compression force measurements
- simple force introduction
- compact small dimensions
- simple installation
- Protection class IP 65
- Accuracy 0.5% of full scale value

Measuring ranges

- 0,01 kN ... 100 kN

Applications

- plant engineering
- production lines
- Measurement and inspection equipment
- Special equipment and machinery construction

Specific information

- Limit load > 300% (option)
- Breaking load >800% (option)
- Calibration control 100% signal
- Sensitivity 1,00 mV/V

Model: 3097

Technical data

| Model | 3097 | Options |
|---|--|--|
| Nominal load F_{nom} | 0,01, 0,02, 0,05, 0,1, 0,2, kN 0,5, 1, 2, 5, 10, 20, 50, 100 kN | Overload protec., 5-fold; ($\leq 0,2\text{kN}$) Overload protec., 3-fold; ($\geq 0,5\text{kN}$) |
| Accuracy class | 0.5% of F.S. | |
| Limit load | 150% F_{nom} | >300% F_{nom} |
| Breaking load | >300% F_{nom} | >800% F_{nom} |
| Combined error | $\leq \pm 0.25\%$ of F.S. | |
| Max. dynamic load | $\pm 70\%$ F_{nom} acc. to DIN 50100 | |
| Creep, 30 min. at F_{nom} | $< \pm 0.1\%$ of F.S. | |
| Nominal deflection | < 0.3 mm | |
| Nominal temperature range | -10 bis +50°C | |
| Service temperature range | -30 bis +80°C | |
| Storage temperature range | -50 bis +95°C | |
| Reference temperature | 23°C | |
| Temperature influence | -span -zero | $\pm 0.2\%$ of F.S./ 10K $\pm 0.2\%$ of F.S./ 10K |
| Protection type (acc. to EN 60 529/IEC 529) | IP 65 | |
| Insulation resistance | > 2 G Ω | |
| Analogue output | | 1.00 mV/V |
| - Output signal | 0.8 ... 1.2 mV/V | |
| - Bridge resistance | 350 Ω | |
| - Option | Cable integrated amplifier 0(4) ...20mA | |
| - Tolerance of span | 0 ... 10 V DC | |
| - Excitation voltage | $\leq \pm 0,5\%$ of F.S. | |
| - Option | 2 ... 12 V (< 100 N = 2 ... 6 V) | |
| - Electrical connection | max. 15 V (< 100 N = 8 V) | |
| | 16 ... 32 V DC for cable integrated amplifier | |
| | Cable 3 m / 4-wire, shielded | |
| Calibration control | | 100% signal |
| Sensitivity | | 1,00 mV/V |
| Material of measuring device | Stainless steel | |
| Weight | | |
| - 3097.100.430 - 3097.100.430 | 0,07 kg | |
| - 3097.100.432 - 3097.100.435 | 0,08 kg | |
| - 3097.100.436 - 3097.100.442 | 0,15 kg | |

of F.S. = full scale value

Dimensions

with overload protection

without overload protection

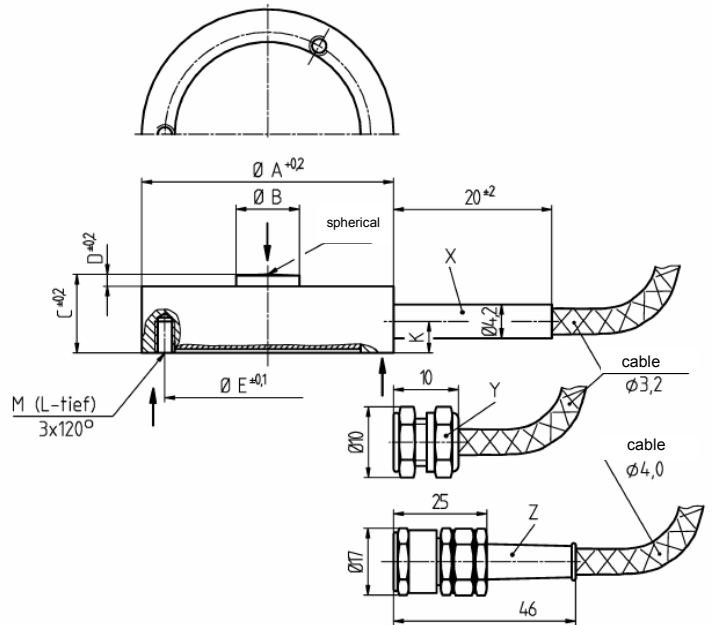
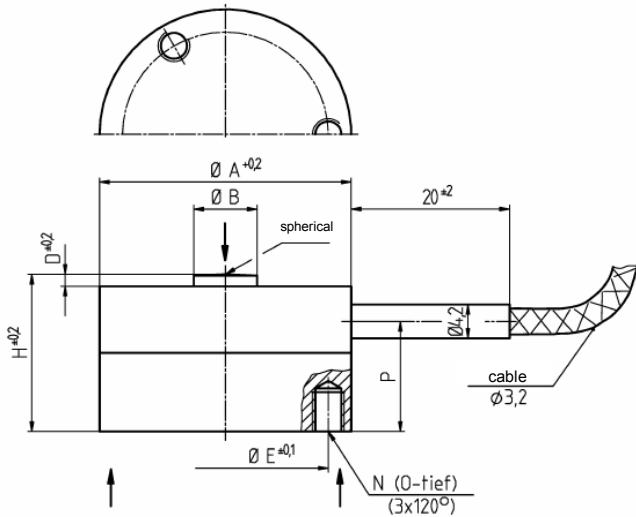

| Measuring range [kN] | Dimensions in [mm] | | | | | | | | | | | | | | |
|---|--------------------|----|----|-----|----|----|---|------|----|---|------|-----|-----|-----|-----|
| | ØA | ØB | C | D | ØE | H | L | M | N | O | P | K | X | Y | Z |
| 0,01, 0.02, 0.05, 0.1, 0.2, 0.5, 1, 2, 5, 10 | 32 | 8 | 10 | 1.8 | 26 | 20 | 4 | M2.5 | M4 | 5 | 14 | 4 | • | --- | --- |
| 20 | 39 | 11 | 16 | 2.0 | 32 | 24 | 5 | M3 | M3 | 5 | 12.5 | 4.5 | --- | • | --- |
| 50 | 52 | 15 | 25 | 3.0 | 42 | 40 | 6 | M4 | M4 | 5 | 25 | 10 | --- | --- | • |
| 100 | 79 | 20 | 39 | 5.0 | 65 | 50 | 6 | M5 | M5 | 6 | 21 | 10 | --- | --- | • |

| Elec. connection | |
|------------------|--------|
| Vers. (-) | green |
| Vers. (+) | brown |
| Sign. (+) | yellow |
| Sign. (-) | white |
| Control | grey |
| Screen | Screen |

Subject of technical changes