

**Product info sheet no. C 2.6 - „Light Version“
 Humidity-/temperature sensors**

for use in air-conditioning systems, building services management systems and ventilation technology

Humidity

measuring range..... 0...100%rh
 sensing element capacitive FE09/4
 accuracy at 23°C (73,4°F) ±3 %RH (40...60%rh)
 at 23°C (73,4°F) ±5 %RH (otherwise)
 working range 15...90%rh
 temperature effect typ. less 0.25%RH per °C/°F
 minimum air speed 1m/sec, 3ft/sec
 Calibration 1 point
 measuring medium
 air, pressureless, non-corrosive, non-condensing
 output 0...10V or 4...20mA

Temperature

measuring range..... 0...50°C (32...122°F)²⁾
 sensing element LM35
 accuracy (10...40°C ; 50...104°F) ±1 °C; ±1.8 °F
 calibration 1 point at 23°C
 output 0...10V or 4...20mA

Other data

power supply:
 current output (KL) (PL) 12...24V DC
 current output (WL) 15...30V DC
 voltage output 24V AC/DC ±10%
 voltage output (duct-version)
 15...30V DC/24V AC ±10%

max. load $\Omega = \frac{\text{supply} - 10 \text{ VDC}}{0,02 \text{ Amps}} \pm 50\Omega$
 (current output only)

min load (voltage output only) 10 kΩ
 ambient temperature KL, PL -20 ...+80°C (-4...176°F)
 WL -20...+60°C (-4...140°F)

electromagnetic compatibility

Emitted interference EN 55011 cl. B
 Noise immunity EN 50082-2
 sensor tube Ø20mm (Ø 0,79“) aluminium
 housing ABS light grey
 protective system WL IP20
 PL, KL (housing) IP54, sensor IP20
 „subject to technical modifications“

Type variants Special types on request

Measured variable	Output	WL series wall mounting	KL series duct installation	PL series rod-shaped
F rel. humidity	0...10 V	FWL2/5	FKL2/5	FPL2/5
	4...20 mA	FWL3/5	FKL3/5	FPL3/5
K r.h. + temperature	2 x 0..10 V	KWL2/5	KKL2/5	KPL2/5
	2 x 4..20 mA	KWL3/5	KKL3/5	KPL3/5
T temperature	0...10 V	TWL2/5	TKL2/5	TPL2/5
	4...20 mA	TWL3/5	TKL3/5	TPL3/5
	Pt100	TWL5/5	TKL5/5	TPL5/5
C r.h. + temp. passive	0...10V + T	CWL2/5-X	CKL2/5-X	CPL2/5-X
	4...20mA + T	CWL3/5-X	CKL3/5-X	CPL3/5-X
Weight		ca. 80g	ca. 330g	ca. 120g

Description

These sensors have been specially adapted to the needs of the ventilation and air-conditioning sector. They come in three series (the WL series for wall mounting, the KL series for duct installation and the PL series with a cable for suspension from any location). The KL and PL series are equipped with gauze filters as standard. Other filters are available on request. Use of capacitive humidity sensor elements is a guarantee of high long-term stability, resistance to dew formation, small hysteresis and good dynamic performance.

User instructions

Install these sensors at a place where characteristic climatic conditions occur. The wall-mounting sensors can be installed on flush-mounted sockets on installation systems and directly onto the wall. Avoid installing them close to heaters or windows or against outside walls. The sensors with the connection cable can be suspended directly from the cable. In principle, the sensors do not require any maintenance. However, the dynamic behaviour of the sensor may be affected if it is exposed to too much dust. In this case, clean the sensor element by blowing the dust off. In the case of the KL and PL series, clean the sensors by rinsing them carefully in distilled water. Never touch the highly sensitive sensor element.

Other signal output temperature

NTC; PTC; KTY; LMx35; Pt100; Pt1000; Ni1000; AD592; LM34; BALKO 1kΩ; SILICON 2kΩ; SEMICONDUCTOR 559 mVDC @23°C (73,4°F) Thermistors @ 25°C (77°F) 1,8kΩ; 2,252kΩ; 3kΩ; 5kΩ; 10kΩ; 1,8kΩ (Type II; III, CSI); 20kΩ; 100kΩ

This information is based on current knowledge and is intended to provide details of our products and their possible applications. It does not, therefore, act as a guarantee of specific properties of the products described or of their suitability for a particular application. It is our experience that the equipment may be used across a broad spectrum of applications under the most varied conditions and loads. We cannot appraise every individual case. Purchasers and/or users are responsible for checking the equipment for suitability for any particular application. Any existing industrial rights of protection must be observed. The perfect quality of our products is guaranteed under our General Conditions of Sale. Issue : February 2004 valid until 31.12.2005 C26_E. Subject to modifications, current version available at www.galltec.de. This issue supersedes all previous technical leaflets.

Connection diagram series KL

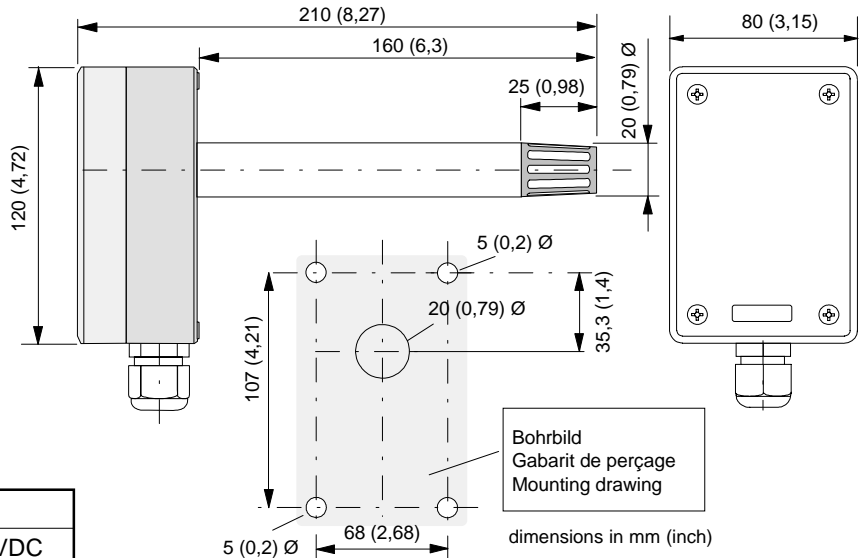

version 0...10VDC

	terminals	ranges
supply	(1-) (2+)	15...30VDC
	(1~) (2~)	24 V AC ±10%
„humidity“	(3) (4+)	0...10VDC
„temperature“	(5) (6+)	0...10VDC
„temperature“	(5) (6)	passive sensor
shield	(7)	
not galvanic disconnected negative pole (1-) (3) (5) = common		

version 4...20mA, 12...30VDC (see diagram load)

	terminals	ranges	Measuring ranges galvanic disconnected
„humidity“	(1-) (2+)	4...20mA	
„temperature“	(3-) (4)	4...20mA	
„temperature“	(3) (4)	passive sensor	
shield	(5)		

Connection diagram series WL

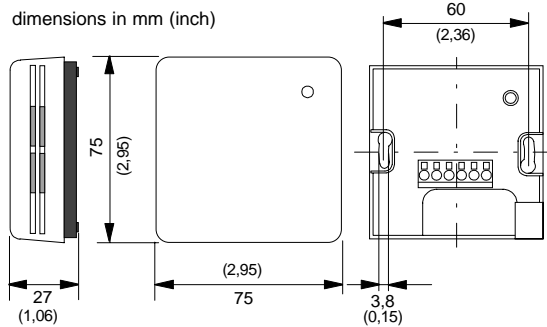

version 0...10VDC

	terminals	ranges
supply	(1-) (2+)	15...24VDC
	(1~) (2~)	24 V AC ±10%
„humidity“	(3) (4+)	0...10VDC
„temperature“	(5) (6+)	0...10VDC
„temperature“	(5) (6)	passive sensor
not galvanic disconnected negative pole (1-) (3) (5) = common		

version 4...20mA, 15...30VDC (see diagram load)

	terminals	ranges	Measuring ranges galvanic disconnected
„humidity“	(1-) (2+)	4...20mA	
„temperature“	(3-) (4)	4...20mA	
„temperature“	(3) (4)	passive sensor	

Connection diagram series PL

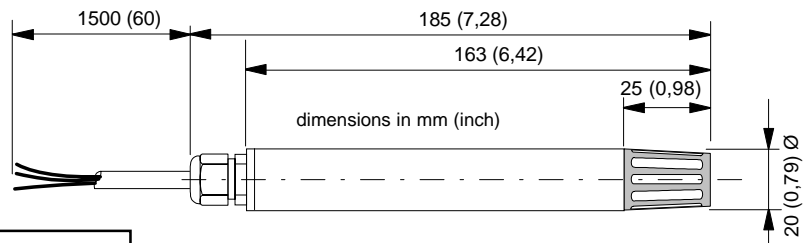

version 0...10VDC

not galvanic disconnected
negative pole (-brown) = common

	wire colour	ranges
supply	(-brown) (+green)	15...30VDC
	(~brown)(~green)	24 V AC ±10%
„humidity“	(-brown) (+white)	0...10VDC
„temperature“	(-brown) (+yellow)	0...10VDC
„temperature“	(blue) (yellow)	passive sensor

version 4...20mA, 12...30VDC (see diagram load)

	wire colour	ranges	Measuring ranges galvanic disconnected
„humidity“	(-green) (+brown)	4...20mA	
„temperature“	(-white) (+yellow)	4...20mA	
„temperature“	(white) (yellow)	passive sensor	