

EE28/EE30 Series EE30EX

Industrial Transmitters for Humidity, Temperature and Correlated Physical Quantities

EE28, EE30 and EE30EX multifunctional transmitter series are designed for high accuracy measurement of humidity and temperature in industrial applications and in climate control.

Various mechanical designs, electronic hardware and software options are available to enable optimal adjustment in nearly every high-end practical application.

The transmitters are fully temperature-compensated, which guarantees exceptional accuracy in the range of 0...100 %RH and -40...+180 degC (-40...356 degF). Models for intrinsically safe applications and for pressure tight installations from 0,01...15 bar complete the range of products.

The core component of the industrial transmitter is the E+E capacitive humidity sensor of the HC series. This grants excellent long term stability, very low hysteresis, and high resistance to chemicals.

In very dirty or corrosive environment we offer special humidity sensor elements with special protective coating developed by E+E.

The analogue output signals for humidity and temperature are available as current or as voltage.

State-of-the-art microprocessor technology makes both analogue outputs free selectable and scaleable via RS232 serial interface.

The communication with a PC is assisted by an user friendly software, running under MS Windows™ which enables the user to change original factory settings easily.



Additional Functions for EE30 and EE30EX Series

Besides measurement of humidity and temperature, EE30 and EE30EX calculate the values of the following physical quantities:

- | | |
|---------------------------|----|
| - dew point temperature | Td |
| - frost point temperature | Tf |
| - wet bulb temperature | Tw |
| - water vapour pressure | e |
| - mixing ratio | r |
| - absolute humidity | dv |
| - specific enthalpy | H |

These are available on the RS 232 serial interface, on the analogue outputs and on the integrated LCD display.

Software Description

EE28 / EE30 / EE30EX transmitters are supplied with a free software running under MS WINDOWS™. This software enables the user to set up his individual transmitter configuration and to run service functions easily from a PC connected to the transmitter via RS232 serial interface. (RS232 cable refer to 'Accessories')

It is also possible to communicate directly with the transmitter via standard terminal software to integrate the EE28/30 into free memory programmed controls.

Freely selectable and scaleable outputs

The user can select the physical quantity on the analogue outputs. (these are: RH and T for the EE28) and additional calculating functions for the EE30 and EE30EX. The type of output signal and the range are freely scaleable and selectable. The measuring interval is individually adjustable.

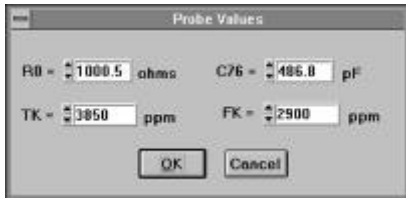

Sensor exchange

If the humidity or the temperature sensor is damaged, it can be replaced easily by the user with E+E spare sensors with individual data. It is not necessary to service the transmitter at the manufacturer. The user just has to type in the data of the new sensor using his PC. (refer to 'Accessories')

Calibration

The software provides one-point calibration procedures for both relative humidity and temperature. The transmitter can be adjusted easily in only one program step. For humidity calibration, E+E offers a reliable reference calibration set (see accessories) as well as the high accuracy certified humidity generator HUMOR 10S.

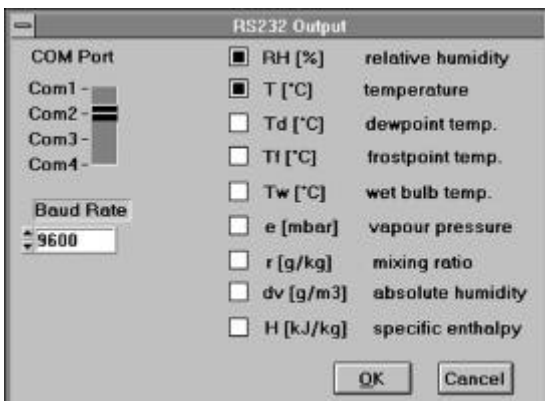
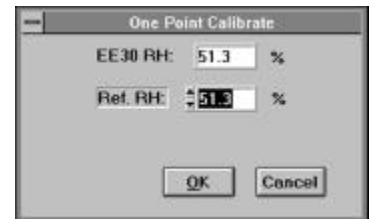

Calculated physical quantities for EE30 and EE30EX

Using the measured values of relative humidity and temperature, EE30 and EE30EX calculate the following physical quantities.

dew point temperature	Td
frost point temperature	Tf
wet bulb temperature	Tw
water vapour pressure	e
mixing ratio	r
absolute humidity	dv
specific enthalpy	H

These quantities can be read on the integrated display (optional), are available as analogue output signals as well as digital on the RS 232C serial interface.

PC Monitoring and logging functions for EE30 and EE30EX

All measured and calculated values can be monitored on-line as digital values, strip chart or continuous output list. Using the data-logging function all these values can be stored as ASCII files. Further processing can be made by all standard calculation software such as Excel.

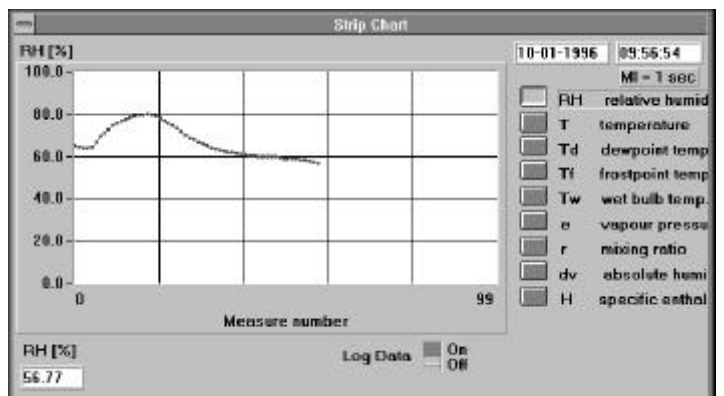

EE28/EE30 Series

EE28 and EE30 transmitters are available in robust aluminium housing or in light weight ABS housing. Both are suitable for wall or duct mounting. They can optionally accommodate an LCD display, integrated 230 VAC supply module, as well as plug connectors or cable glands. The design with remote sensor probe on a flying lead up to 10 meters is the solution for high temperature applications, for small space requirements or for pressure tight applications.

Typical Applications _____ Features _____ Housing

EE28-xAx/EE301 - wall mounting

reference device
 laboratory equipment
 climate chambers
 clean rooms

working range -40...60 degC
 highest accuracy
 software calibration
 serial interface



EE28-xBx/EE302 - duct mounting

demanding HVAC system
 laboratory equipment
 climate chambers
 clean rooms

working range -40...80 degC
 highest accuracy
 software calibration
 serial interface



EE28-xCx/EE303 - up to 120degC

reference device
 drying processes

working range -40...120 degC
 easy mounting facilities
 full temperature compensation
 remote sensing probe up to 10 m



EE28-xDx/EE304 - for high temperature

drying processes
 wood, pasta, brick and
 laundry dryers

working range -40...180 degC
 easy mounting facilities
 full temperature compensation
 remote sensing probe up to 10 m



EE28-xEx/EE305 - for high and low pressure

compressed air line
 piping
 boilers
 vacuum drying oven

pressure tight range 0,01...15 bar
 working range -40...180 degC
 remote sensing probe up to 10 m



Housing Dimensions (mm)

Plastic housing

Material: ABS

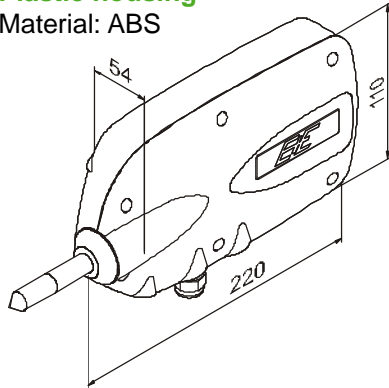

Metal housing

Material: Aluminium

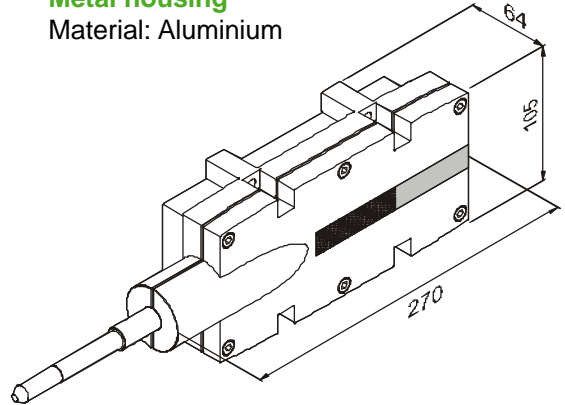

Probe Dimensions (mm)

Version EE301 and EE28-xAx

Wall mounting

Probe material: stainless steel

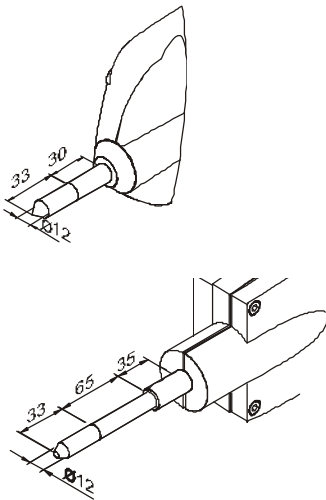

Version EE302 and EE28-xBx

Duct mounting

Probe material: stainless steel

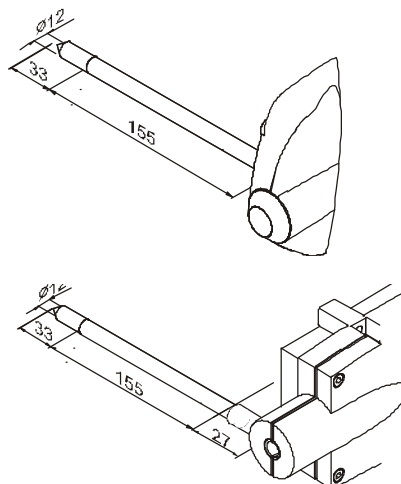

Version EE303 and EE28-xCx

Measuring up to 120degC

Probe material: stainless steel

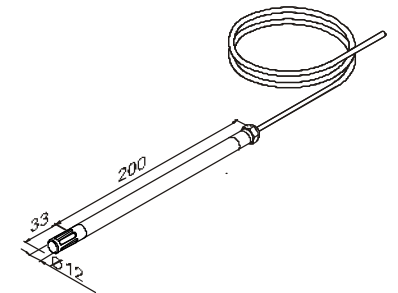

Version EE304 and EE28-xDx

High temperature version

Probe material: stainless steel

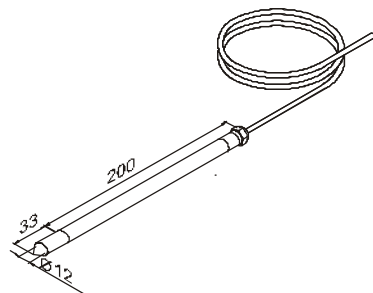

Version EE305 and EE28-xEx

Pressure-tight probe

Probe material: stainless steel

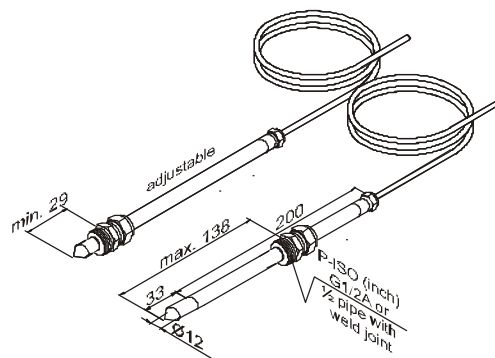

Technical Data EE28

Measuring values

Relative humidity

Humidity sensor ¹⁾	HC1000-400 or HC 1000-400C	
Working range ¹⁾	0...100 %RH	
Accuracy incl. hysteresis and nonlinearity		
- with special calibration against certified standards	± 1 %RH (0...90 %RH)	± 2 %RH (90...100 %RH)
- standard calibration	± 2 %RH (0...90 %RH)	± 3 %RH (90...100 %RH)
Guaranteed accuracy limits - GAL 23 according standard NFX15.113	for range: 0-90 % RH :	2.35 % RH
	for range: 0-100 % RH :	2.96 % RH
Temperature dependence electronics	typ. 0.06 %RH/degC	
Temperature dependence sensor probe	typ. 0.03 %RH/degC	
Response time with filter at 20 degC / t ₉₀	< 30 sec.	
Response time without filter at 20 degC / t ₉₀	< 10 sec.	

Temperature

Temperature sensor element	Pt1000 (class A, DIN EN 60751)	
Working range (according to type of sensor probe)	-40..60 (80,120,180) degC [-40...140 (176,248,356) °F]	
Accuracy (typ.)		

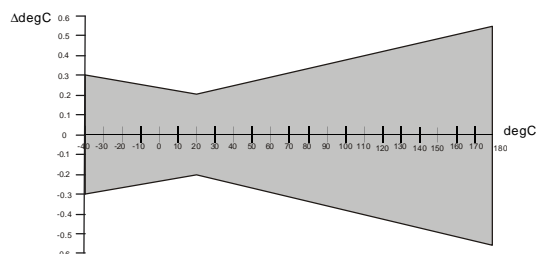

Temperature dependence of electronics	typ. 0.005 degC/degC	
---------------------------------------	----------------------	--

Outputs

Two freely selectable and scaleable outputs	0 - 5 V	-1 mA < I _L < 1 mA
0...100 %RH / -40...60 (80,120,180) degC analogue	0 - 10 V	-1 mA < I _L < 1 mA
	4 - 20 mA	R _L < 360 Ohm

General

Supply voltage	SELV 24 VDC/VAC ± 15 %	
Optional power supply unit (only for metal housing)	100 - 260 VAC / 50-60 Hz max.	
Current consumption - two voltage outputs	for 24VDC/AC: typ. 60 mA	for 100-260VAC: typ. 25 mA
- two current outputs	typ. 100 mA	typ. 25 mA
Pressure range with pressure tight sensor probe	0.01...15 bar	
System requirements for communication-software	IBM compatible AT, 386/33 MHz or higher (with coprocessor), 5 MB free hard disk memory, 4 MB RAM, 3.5 " disk drive, serial interface, mouse (recommended), MS WINDOWS 3.1 or higher	
Housing	cast aluminium or ABS-plastic / IP65	
Cable gland ²⁾	PG 9; for cable diameter 5 - 9 mm	
Electrical connection ²⁾	screw terminals max. 1.5 mm ²	
Sensor protection	sintered stainless steel filter, PTFE filter or metal grid filter	
Working temperature range, electronic	-40...+60 degC (-40..140 °F)	
Storage temperature range	-30...+60 degC (-22..140 °F)	
Working and storage temperature range housing with display	0...+40 degC (32..104 °F)	
Electromagnetic compatibility according	EN50081-2	EN50081-1
	EN50082-2	EN50082-1

¹⁾ Refer to the working range of the humidity sensor!

²⁾ Connection plugs refer to 'Accessories'!

Technical Data EE30

Measuring values

Relative humidity

Humidity sensor ¹⁾	HC1000-400 or HC 1000-400C	
Working range ¹⁾	0...100 %RH	
Accuracy incl. hysteresis and nonlinearity with calibration against certified standards standard calibration	± 1 %RH (0...90 %RH) ± 2 %RH (0...90 %RH)	± 2 %RH (90...100 %RH) ± 3 %RH (90...100 %RH)
Guaranteed accuracy limits - GAL 23 according standard NFX15.113	for range: 0-90 % RH :	2.35 % RH 2.96 % RH
Temperature dependence electronics	typ. 0.06 %RH/degC	
Temperature dependence sensor probe	typ. 0.03 %RH/degC	
Response time with filter at 20 degC / t_{90}	< 30 sec.	
Response time without filter at 20 degC / t_{90}	< 10 sec.	

Temperature

Temperature sensor element	Pt1000 (class A, DIN EN 60751)
Working range (according to type of sensor probe)	-40..60 (80,120,180) degC [-40..140 (176,248,356) °F]
Accuracy (typ.)	

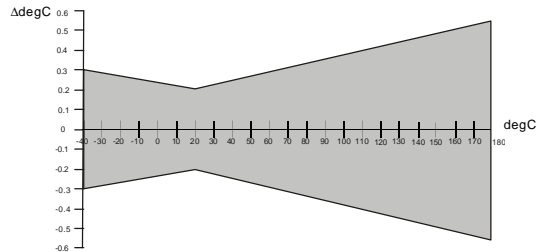

Temperature dependence of electronics	typ. 0.005 degC/degC
---------------------------------------	----------------------

Outputs

Two freely selectable and scaleable outputs	0 - 5 V	-1 mA < I_L < 1 mA
	0 - 10 V	-1 mA < I_L < 1 mA
	4 - 20 mA	R_L < 360 Ohm
Serial interface	RS 232C	

Standard Measurement Range ^{2) 3)}

		from	to					unit
				EE301	EE302	EE303	EE304/305	
Humidity	RH	0	100	100	100	100	100	%RH
Temperature	T	-40 (-40)	60 (140)	80 (176)	120 (248)	180 (356)	180 (356)	degC (°F)
Dew point temperature	Td	-40 (-40)	60 (140)	80 (176)	100 (212)	100 (212)	100 (212)	degC (°F)
Frost point temperature	Tf	-40 (-40)	0 (32)	0 (32)	0 (32)	0 (32)	0 (32)	degC (°F)
Wet bulb temperature	Tw	0 (32)	60 (140)	80 (176)	100 (212)	100 (212)	100 (212)	degC (°F)
Water vapour pressure	e	0 (0)	200 (3)	500 (7.5)	1000 (14,5)	1000 (14,5)	1000 (14,5)	mbar (psi)
Mixing ratio	r	0 (0)	425 (2900)	500 (3500)	500 (3500)	500 (3500)	500 (3500)	g/kg (gr/lb)
Absolute humidity	dv	0 (0)	150 (60)	300 (150)	600 (262)	600 (262)	600 (262)	g/m ³ (gr/ft ³)
Specific enthalpy	H	-40 (-13000)	400 (150000)	1000 (350000)	1500 (500000)	1500 (500000)	1500 (500000)	kJ/kg (lbf/lb)

Max. adjustable Measurement Range ³⁾

		from	to					unit
				EE301	EE302	EE303	EE304/305	
Humidity	RH	0	100	100	100	100	100	%RH
Temperature	T	-40 (-40)	60 (140)	80 (176)	120 (248)	180 (356)	180 (356)	degC (°F)
Dew point temperature	Td	-80 (-112)	60 (140)	80 (-112)	100 (212)	100 (212)	100 (212)	degC (°F)
Frost point temperature	Tf	-80 (-112)	0 (32)	0 (32)	0 (32)	0 (32)	0 (32)	degC (°F)
Wet bulb temperature	Tw	0 (32)	60 (140)	80 (176)	100 (212)	100 (212)	100 (212)	degC (°F)
Water vapour pressure	e	0 (0)	200 (3)	500 (7.5)	1100 (15)	1100 (15)	1100 (15)	mbar (psi)
Mixing ratio	r	0 (0)	425 (2900)	999 (9999)	999 (9999)	999 (9999)	999 (9999)	g/kg (gr/lb)
Absolute humidity	dv	0 (0)	150 (60)	300 (150)	700 (300)	700 (300)	700 (300)	g/m ³ (gr/ft ³)
Specific enthalpy	H	-50 (-15000)	400 (150000)	1000 (350000)	2800 (999999)	2800 (999999)	2800 (999999)	kJ/kg (lbf/lb)

¹⁾ Refer to the working range of the humidity sensor. ²⁾ Can be easily changed by software. ³⁾ Refer to accuracies of calculated values.

General

Supply voltage	SELV 24 VDC/VAC ± 15 %		
Optional power supply unit (only for metal housing)	100 - 260 VAC / 50-60 Hz max.		
Current consumption	- two voltage outputs	for SELV: typ. 60 mA	for main supply: typ. 25 mA
	- two current outputs	typ. 100mA	typ. 25 mA
System requirements for communication-software	IBM compatible AT, 386/33 MHz or higher (with coprocessor), 5 MB free hard disk memory, 4 MB RAM, 3.5 " disk drive, serial interface, mouse (recommended), MS WINDOWS 3.1 or higher		
Pressure range with pressure tight sensor probe	0.01...15 bar		
Housing	cast aluminium or ABS-plastic / IP65		
Cable gland ²⁾	PG 7 and PG 9; for cable diameter 5 - 9 mm		
Electrical connection ²⁾	screw terminals max. 1.5 mm ²		
Sensor protection	sintered stainless steel filter, PTFE filter or metal grid filter		
Working temperature, electronics	-40 ... +60 degC (-40..140 °F)		
Storage temperature range	-30 ... +60 degC (-22..140 °F)		
Working and storage temperature range housing with display	0 ... +40 degC (32..104 °F)		
Electromagnetic compatibility according	EN50081-2	EN50081-1	■
	EN50082-2	EN50082-1	■

Working Range Humidity Sensor

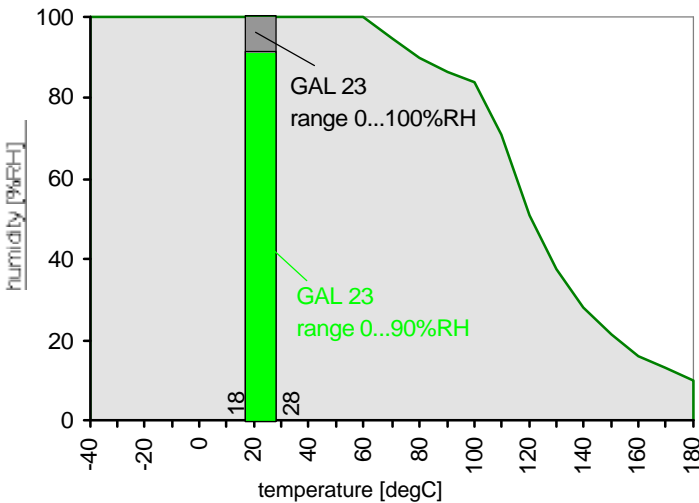

The specified working range for the humidity sensor element is shown in terms of humidity/temperature limits.

Although the sensors would not deteriorate beyond the limits, their performance can only be specified within the limits for the working range.

Sensing head with protective coating

For use in heavy polluted or aggressive environment E+E has developed a special protective coating process (order code -HC). Both humidity and temperature sensor elements are covered with a polymer film. Extensive tests have proved an amazing improvement of the resistance to chemical pollutants which leads to a much better long term stability of the transmitter.

Connecting Diagram

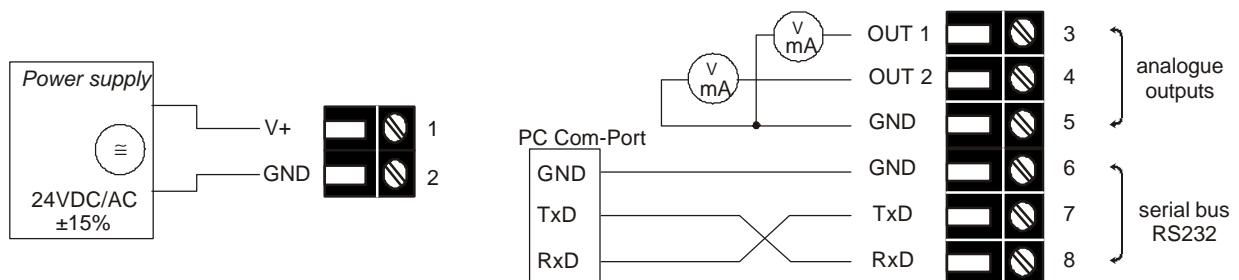

²⁾ Connection plugs refer to 'Accessories'!

EE30EX Series

Humidity/Temperature Transmitter for Intrinsically Safe Applications

EE30EX Series Transmitters from E+E Elektronik are designed for the accurate measurement of humidity and temperature in the range between 0..100 %RH and -40...+180 degC.

EE30EX meets the **ATEX requirements** and complies to the following health and safety standards of intrinsically safe machinery:

EN50014 :1997

EN50020 :1994

EN50284 :1998



The EC type examination was carried out by Physikalisch-Technische Bundesanstalt (PTB), the German national institute for science and technology.

The transmitters of EE30EX series consist of:

- supply and evaluation unit, classified according to **II(1)G [Ex ia] IIC** subject to EC-type examination certificate **PTB 99 ATX 2042**.
- sensor driver unit and sensor probe, classified according **II1/2G EEx ia IIC 1G T6** subject to EC-type examination certificate **PTB 99 ATX 2043 X**.

The sensor probe can be employed in zone 0 and in temperature class T6. (apparatus group II, category 1). For EE30EX version B the cable length between sensing probe and sensor driver unit can be up to 10m. The maximum length of the cable between the supply and evaluation unit and the sensor driver unit is 100 m.

There are three versions available:

Version A: wall mounting in explosive zone 1 or 2

Version B: separated sensor head (up to 10 m) for installation directly in the partition wall

Version E: separated sensor head (up to 10 m) for high pressure environment between 0.8...15 bar



Model A



Model B



Model E

Typical Applications _____ Features

chemical processes
 pharmaceutical applications
 explosive endangered storage rooms

EC-Type examination acc. ATEX
 approved for zone 0
 highest accuracy up to 180 degC
 dew point, absolute humidity,... measurement
 incl. MS Windows™ Software
 interchangeable humidity sensor

Versions _____

Model A
 for wall mounting

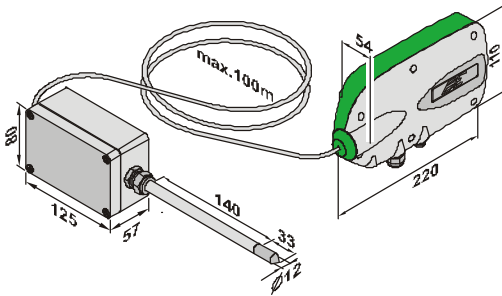

The sensing probe is mounted on to the sensor driver unit and can be installed in zone 1 or zone 2.

Working range sensing probe: -20...60 degC
 Working range electronics: -20...60 degC

Model B
 with separated sensing probe for mounting direct in the partition wall

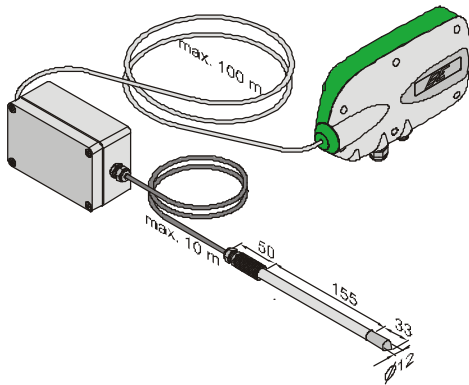

The sensor driver unit can be installed in zone 1 or zone 2. The remote sensing probe (up to 10m) can be installed directly in the partition wall to the next higher Ex-zone.

The mounting is done with a feedthrough which corresponds to the Ex-requirements. The feedthrough is included in the scope of supply.

Working range sensing probe: -40...180 degC
 Working range electronics: -20...60 degC

Model E
 For pressure tight applications

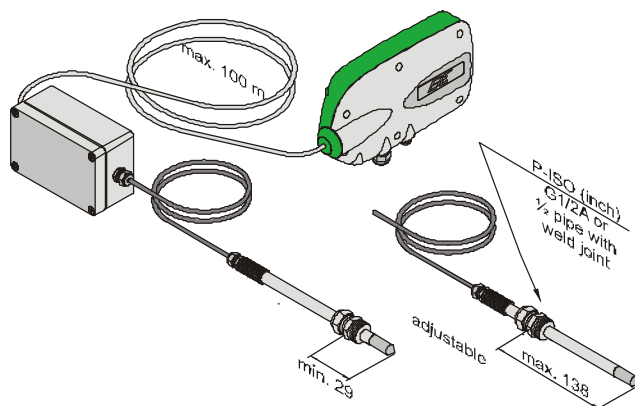

The sensing head is designed to operate in the pressure range 0.8 ...15 bar.

Technical Data EE30EX

Measuring values

Relative humidity

Humidity sensor ¹⁾	HC1000-400	
Measuring range ¹⁾	0...100 %RH	
Accuracy incl. hysteresis and nonlinearity		
-with special calibration against certificated standards	± 1%RH (0...90 %RH)	± 2 %RH (90...100 %RH)
-standard calibration	± 2 %RH (0...90 %RH)	± 3 %RH (90...100 %RH)
Guaranteed accuracy limits - GAL 23 according standard NFX15.113	for range: 0-90 % RH :	2.35 % RH
	for range: 0-100 % RH :	2.96 % RH
Temperature dependence electronic	typical 0.06 %RH/degC	
Temperature dependence sensor head	typ. 0.03 %RH/degC	
Response time with filter at 20 degC / t ₉₀	< 30 sec.	

Temperature

Temperature sensor	Pt1000 (DIN EN 60751, class A)	
Measuring range sensor head	EE30EX-A -20...60 degC (-4...140 °F)	EE30EX-B -40...180 degC (-40...356 °F)
	EE30EX-E -40...180 degC (-40...356 °F)	

Accuracy (typ.)

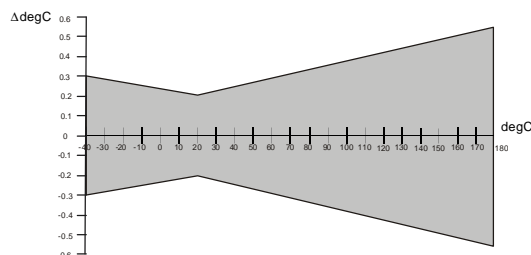

Temperature dependence typical 0.005 degC/degC

Standard Measurement Range for calculating functions^{2) 3)}

Humidity	RH	0...100 %RH	Temperature	T	-20... 60 degC (-4...140 °F)
Dew point temperature	Td	-20...60 degC (-4...140°F)	Mixing ratio	r	0...425 g/kg (0...2900 gr/lb)
Frost point temperature	Tf	-20... 0 degC (-4...32°F)	Absolute humidity	dv	0...150 g/m ³ (0...60 gr/ft ³)
Wet bulb temperature	Tw	0... 60 degC (32...140°F)	Specific enthalpy	H	-20...400 kJ/kg (-6600..135000 lbf/ft ³)
Water vapour pressure	e	0...200 mbar (0...2,9psi)			

Outputs

Two freely selectable and scalable outputs	0 - 5 V	-1 mA < I _L < 1 mA
	0 - 10	-1 mA < I _L < 1 mA
	4 - 20 mA	RL < 360 Ohm

Serial interface RS 232C

General

Supply voltage	SELV 24 VDC/VAC ±15%	
Current consumption	≤ 150mA (24 VDC); ≤ 280mA (24 VAC)	
Pressure range with pressure tight sensor probe	0.01...15 bar	
System requirements for	IBM compatible AT, 386/33 MHz or higher (with coprocessor), 5 MB free hard disk memory, 4 MB RAM, 3.5 " disk drive, serial interface, mouse (recommended), MS WINDOWS 3.1 or higher	
Housings	supply- and evaluation unit	ABS-plastic / IP65
	sensor driver unit	AlSi12 / IP65
Cable gland	PG 7 and PG 9; for cable diameter 5 - 9 mm	
Electrical connection	screw terminals max. 1.5 mm ²	
Sensor protection	sintered stainless steel filter	
Temperature range	sensor probe:	according measuring range
	electronic sensor driver device:	-20...60 degC (-4...140°F)
	electronic supply- and evaluation device:	-20...60 degC (-4...140°F)
	electronic with display:	0...40 degC (32...104°F)
Storage temperature range	electronics and sensor head	-30...60 degC (22...140°F)
Electromagnetic compatibility according	EN50081-2	
	EN50082-2	

¹⁾ Refer to the working range of the humidity sensor! (data sheet EE28/EE30)

²⁾ Can be easily changed by software. (maximum adjustable range see 'EE30')

³⁾ Refer to accuracies of calculated values.



Connection Diagram

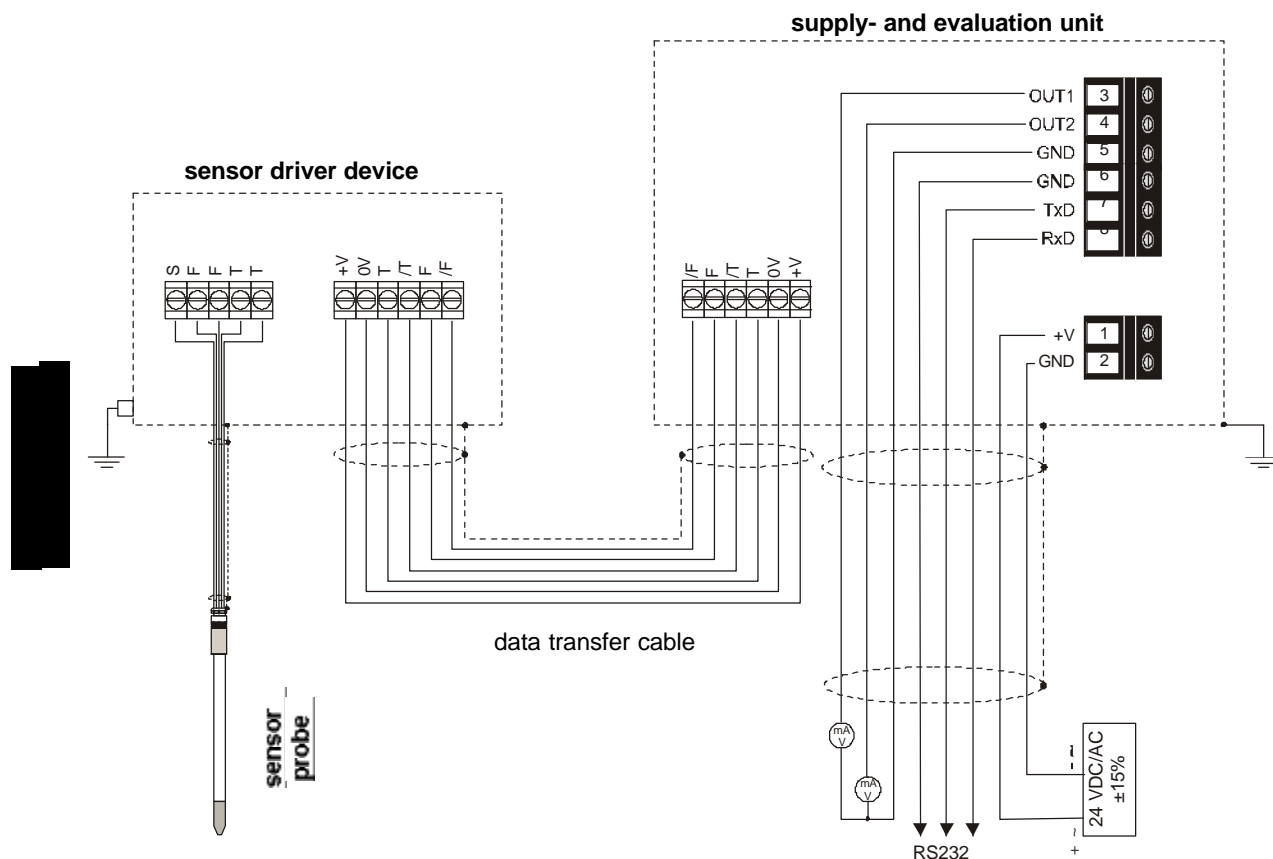

Installation

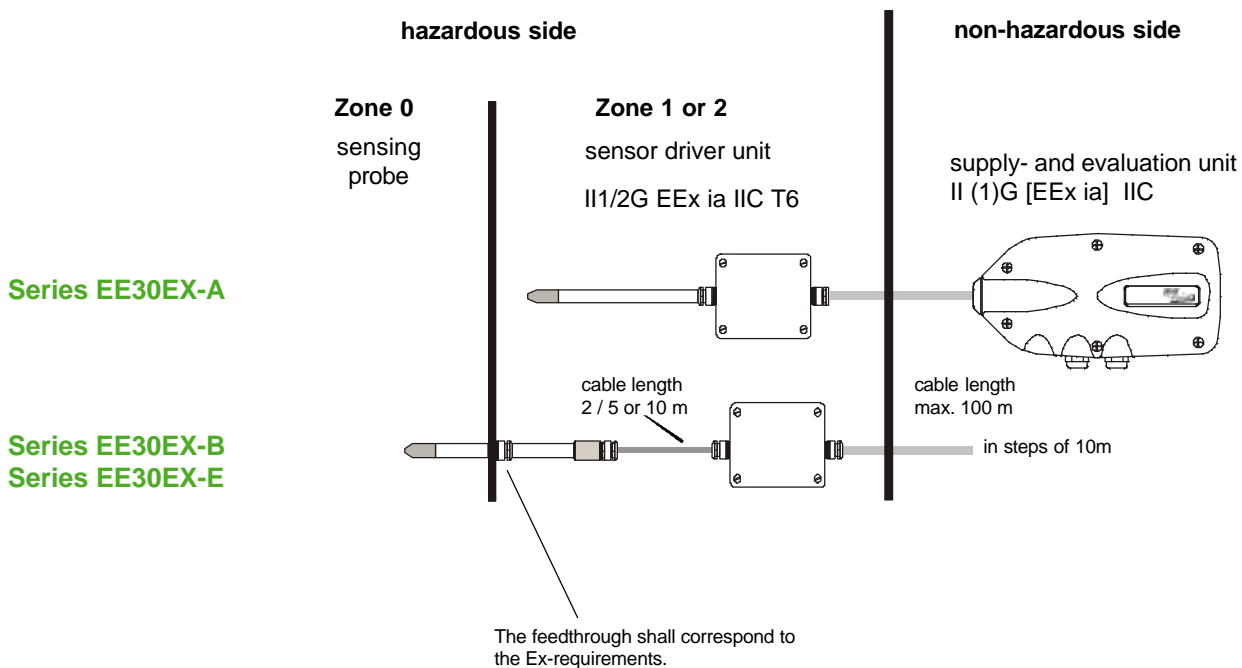

Accuracies of Calculated Variables

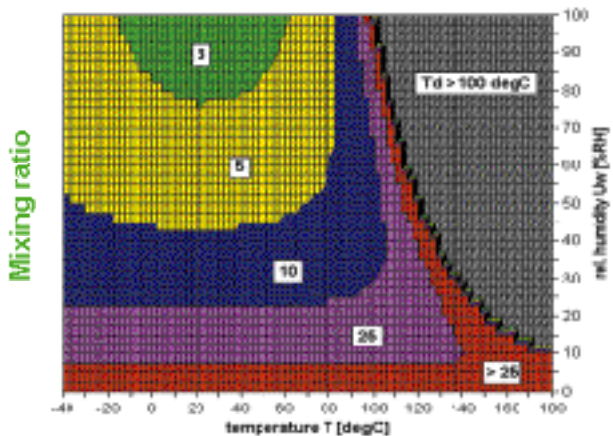
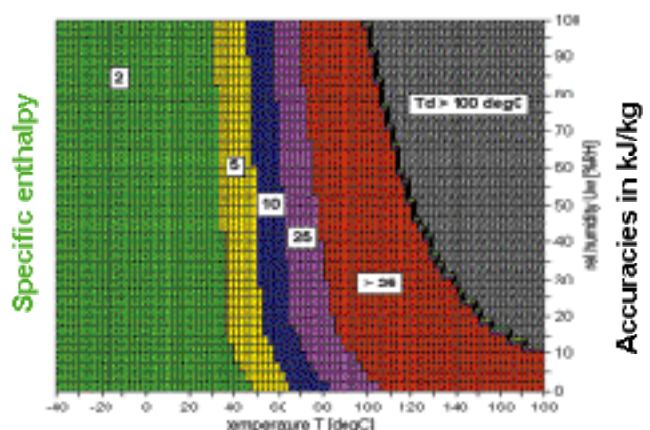
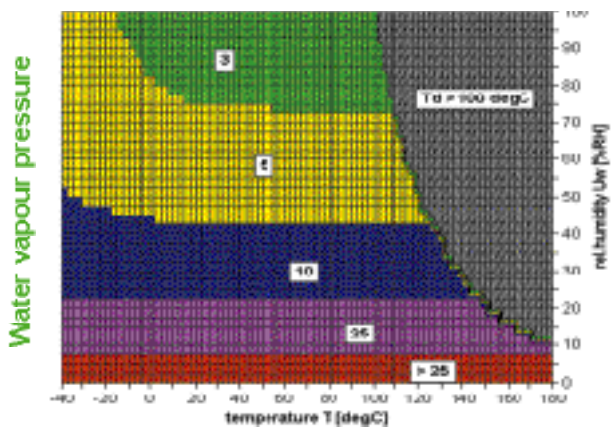
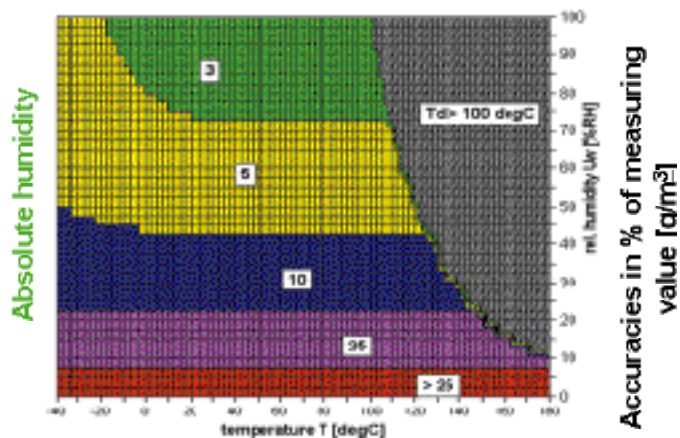
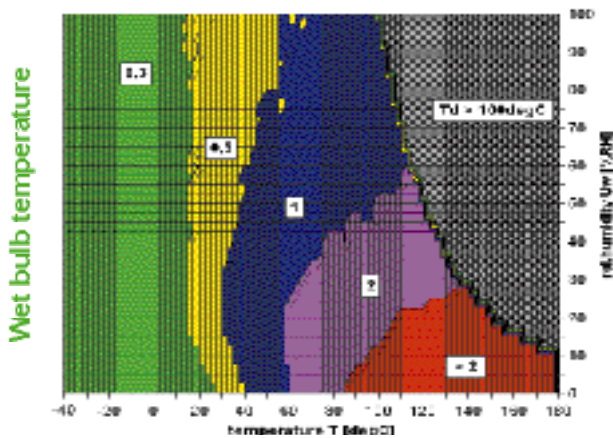
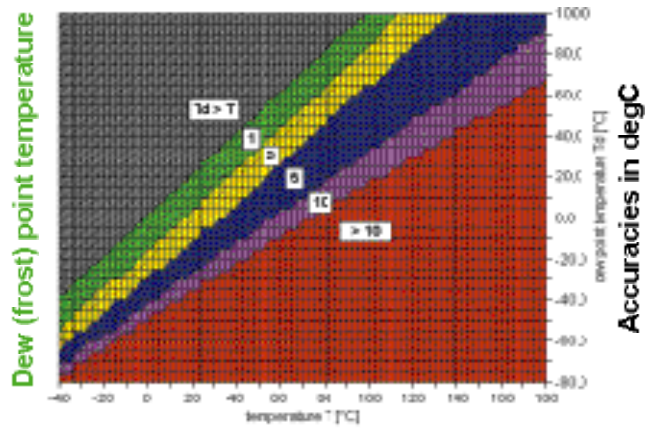
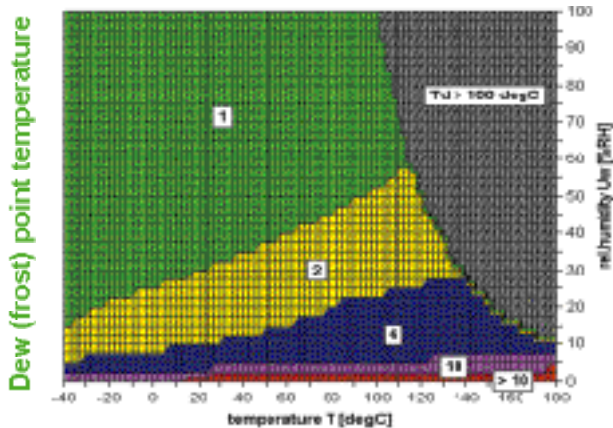

Ordering Guide EE28

Order Code - Hardware Settings

HOUSING	MODEL	FILTER	CABLE LENGTH (only for EE28-xCx/ xDx/ xEx)	PROBE LENGTH	PRESSURE-TIGHT FEEDTHROUGH (only for EE28-xEx)
plastic housing (P)	wall mounting up to 60 degC (140 °F)	sintered stainless steel filter (A)	2 m (02)	standard length (no Code) (see probe dimensions)	with 1/2-inch male thread (HA03)
metal housing (M)	duct mounting up to 80 degC (176 °F)	PTFE-filter (B)	5 m (05)	others in mm (xxx) (on request)	with 1/2-pipe weld joint (HA05)
	separated sensor probe up to 120 degC (248 °F)	metal grid filter (C)	10 m (10)		with 1/2-inch NPT thread (HA07)
	separated sensor probe up to 180 degC (356 °F)				
	separated pressure-tight sensor probe up to 15 bar				
EE28-					

DISPLAY	CONNECTOR	HUMIDITY SENSOR	CALIBRATION
no display (no code)	one standard cable gland PG 9 (no code)	HC1000-400 (no code)	no special calibration (no code)
display (D01)	one plug for supply and outputs (C03)	HC1000-400C (HC01)	high humidity calibration (CA01)
	two plugs for supply + outputs and RS 232 (C07)		

Code for software settings

OUTPUT 1	OUTPUT 2	UNITS (of measured values)	RANGE FOR TEMPERATURE OUTPUT SCALING
0 - 5 V (2)	0 - 5 V (2)	metric (SI-units) (no code)	-40...60 degC (-40...140°F) (T02)
			-10...50 degC (14...122°F) (T03)
0 - 10 V (3)	0 - 10 V (3)	no metric (E01)	0...50 degC (32...122°F) (T04)
			0...100 degC (32...212°F) (T05)
4 - 20 mA (6)	4 - 20 mA (6)		0...60 degC (32...140°F) (T07)
			-30...70 degC (-22...158°F) (T08)
			-30...120 degC (-22...248°F) (T09)
			-20...120 degC (-4...248°F) (T10)
			-40...120 degC (-40...248°F) (T12)
			-20...100 degC (-4...212°F) (T14)
			+20...120 degC (68...248°F) (T15)
			0...120 degC (32...248°F) (T16)
			0...80 degC (32...176°F) (T21)
			-40...80 degC (-40...176°F) (T22)
			-20...80 degC (-4...176°F) (T24)
			-40...160 degC (-40...320°F) (T33)
			+20...140 degC (68...284°F) (T40)
			-40...180 degC (-40...356°F) (T52)

Order example

EE28-PA6/66-T02

humidity/temperature transmitter EE28 series

model: EE28
housing: plastic
model: wall mounting
filter: metal grid
probe length: standard (30 mm)

output 1: 4 - 20 mA
output 2: 4 - 20 mA
temperature output: -40...+60 degC

EE28-ME305HA03/33-T52

humidity/temperature transmitter EE28 series

model: EE28
housing: metal
model: separated pressure-tight sensing probe up to 15 bar
filter: sintered stainless steel filter
cable length: 5 m
probe length: standard (200 mm)
HA03: 1/2 inch male thread

output 1: 0 - 10 V
output 2: 0 - 10 V
temperature output: -40...+180 degC

Ordering Guide EE30

Order Code - Hardware Settings

MODEL	HOUSING	FILTER	CABLE LENGTH (only for EE303 304/305)	PROBE LENGTH	PRESSURE-TIGHT FEEDTHROUGH (only for EE305)
wall mounting up to 60degC (140°F) (EE301)	plastic housing (P) metal housing (M)	sintered stainless steel filter (3) PTFE-filter (5) metal grid filter (6)	2 m (02) 5 m (05) 10 m (10)	standard length (no Code) (see drawing) others in mm (xxx) (on request)	with 1/2-inch male thread (HA03) with 1/2-pipe weld joint (HA05) with 1/2-inch NPT thread (HA07)
duct mounting up to 80degC (176°F) (EE302)					
separated sensor probe up to 120degC (248°F) (EE303)					
separated sensor probe up to 180degC (356°F) (EE304)					
separated pressure-tight sensor probe up to 15 bar (EE305)					
EE30x-					

DISPLAY	CONNECTOR	HUMIDITY SENSOR	CALIBRATION
no display (no code)	standard cable 2 glands PG 9 + PG 7 (no code)	HC1000-400 (no code)	no special calibration (no code)
display (D01)	one plug for supply and outputs (C03) two plugs for supply + outputs and RS 232 (C07)	HC1000-400C (HC01)	high humidity calibration (CA01)

Code for software settings

SETTING FOR OUTPUT 1

relative humidity	RH	[%]	[%]	(A)
temperature	T	[degC]	[°F]	(B)
dew point temperature	Td	[degC]	[°F]	(C)
frost point temperature	Tf	[degC]	[°F]	(D)
wet bulb temperature	Tw	[degC]	[°F]	(E)
water vapour pressure	e	[mbar]	[psij]	(F)
mixing ratio	r	[g/kg]	[gr/lb]	(G)
absolute humidity	dv	[g/m³]	[gr/ft³]	(H)
specific enthalpy	H	[kJ/kg]	[lbf/lb]	(J)

SETTING FOR OUTPUT 2

relative humidity	RH	[%]	[%]	(A)
temperature	T	[degC]	[°F]	(B)
dew point temperature	Td	[degC]	[°F]	(C)
frost point temperature	Tf	[degC]	[°F]	(D)
wet bulb temperature	Tw	[degC]	[°F]	(E)
water vapour pressure	e	[mbar]	[psij]	(F)
mixing ratio	r	[g/kg]	[gr/lb]	(G)
absolute humidity	dv	[g/m³]	[gr/ft³]	(H)
specific enthalpy	H	[kJ/kg]	[lbf/lb]	(J)

OUTPUT 1	OUTPUT 2	UNIT (of measured values)	TEMPERATURE RANGES T or Td
0 - 5 V (2)	0 - 5 V (2)	metric (no code)	-40...60 degC (-40...140°F) (T02) -10...50 degC (14...122°F) (T03) 0...50 degC (32...122°F) (T04) 0...100 degC (32...212°F) (T05) 0...60 degC (32...140°F) (T07) -30...70 degC (-22...158°F) (T08) -30...120 degC (-22...248°F) (T09) -20...120 degC (-4...248°F) (T10) -40...120 degC (-40...248°F) (T12)
0 - 10 V (3)	0 - 10 V (3)	no metric (E01)	-20...100 degC (-4...212°F) (T14) +20...120 degC (68...248°F) (T15) 0...120 degC (32...248°F) (T16) 0...80 degC (32...176°F) (T21) -40...80 degC (-40...176°F) (T22) -20...80 degC (-4...176°F) (T24) -40...160 degC (-40...320°F) (T33) +20...140 degC (68...284°F) (T40) -40...180 degC (-40...356°F) (T52)
4 - 20 mA (6)	4 - 20 mA (6)		

Order Example

EE304-P310/CB36-T52-Td05

humidity/ temperature transmitter EE30 series

model: 304
housing: plastic
filter: sintered stainless steel
cable length: 10 m
probe length: standard 200 mm

setting for output 1: dew point temperature
setting for output 2: temperature
output 1: 0 - 10 V
output 2: 4 - 20 mA
units of measurements: metric
temperature output: -40 ... +180 degC
dew point temperature output: 0 ... +100 degC

Ordering Guide EE30EX

Order code

MODEL	CABLE LENGTH - SENSOR PROBE (only model B and E)		CABLE LENGTH - DATA CABLE		FEEDTHROUGH (only model B / C and E)	DISPLAY (according to software code)
wall mounting (A)	2 m	(02)	2 m	(K02)	with 1/2 inch male thread (HA03)	no display (no code)
separated sensor probe for installation in zone-bulkhead (B)	5 m	(05)	5 m	(K05)	with 1/2 pipe weld joint (HA05)	display (D01)
separated pressure-tight sensor probe between 0.01 ... 15 bar (E)	10 m	(10)	10 m	(K10)	with 1/2 inch NPT thread (HA07)	
			20 m	(K20)		
			in steps of 10 m up to max. 100 m	(Kxx)		
EE30EX-						

Code for software settings

SETTING FOR OUTPUT 1			
relative humidity	RH [%]	[%]	(A)
temperature	T [degC]	[°F]	(B)
dew point temperature	Td [degC]	[°F]	(C)
frost point temperature	Tf [degC]	[°F]	(D)
wet bulb temperature	Tw [degC]	[°F]	(E)
water vapour pressure	e [mbar]	[psi]	(F)
mixing ratio	r [g/kg]	[gr/lb]	(G)
absolute humidity	dv [g/m³]	[gr/ft³]	(H)
specific enthalpy	H [kJ/kg]	[lbf/lb]	(J)

SETTING FOR OUTPUT 2			
relative humidity	RH [%]	[%]	(A)
temperature	T [degC]	[°F]	(B)
dew point temperature	Td [degC]	[°F]	(C)
frost point temperature	Tf [degC]	[°F]	(D)
wet bulb temperature	Tw [degC]	[°F]	(E)
water vapour pressure	e [mbar]	[psi]	(F)
mixing ratio	r [g/kg]	[gr/lb]	(G)
absolute humidity	dv [g/m³]	[gr/ft³]	(H)
specific enthalpy	H [kJ/kg]	[lbf/lb]	(J)

OUTPUT 1	OUTPUT 2	UNIT (of measured values)	TEMPERATURE RANGES
0 - 5 V (2)	0 - 5 V (2)	metric (no code)	-40...60 degC (-40...140°F) (T02)
			-20...100 degC (-4...212°F) (T14)
			+20...120 degC (68...248°F) (T15)
0 - 10 V (3)	0 - 10 V (3)	no metric (E01)	0...50 degC (32...122°F) (T04)
			0...120 degC (32...248°F) (T16)
			0...100 degC (32...212°F) (T05)
			0...80 degC (32...176°F) (T21)
4 - 20 mA (6)	4 - 20 mA (6)		0...60 degC (32...140°F) (T07)
			-40...80 degC (-40...176°F) (T22)
			-30...70 degC (-22...158°F) (T08)
			-20...80 degC (-4...176°F) (T24)
			-30...120 degC (-22...248°F) (T09)
			-40...160 degC (-40...320°F) (T33)
			-20...120 degC (-4...248°F) (T10)
			+20...140 degC (68...284°F) (T40)
			-40...120 degC (-40...248°F) (T12)
			-40...180 degC (-40...356°F) (T52)

Order Example

EE30EX-B02K40HA03/AB66-T02

intrinsically safe humidity/ temperature transmitter EE30EX series

model:	separated sensor probe for installation in the zone-partition wall
cable length for sensor probe:	2 m
cable length for data cable:	40 m
feedthrough:	with 1/2 inch male thread
setting for output 1:	relative humidity
setting for output 2:	temperature
output 1:	4 - 20 mA
output 2:	4 - 20 mA
units of measurements:	metric
temperature output:	-40 ... +60 degC