

## EE23 Series

The EE23 series stands for multifunctionality, highest accuracy, easy mounting and service.

The new IP65 water proof housing concept is based on three modules:

- back module with connectors
- middle module which accommodates the electronics
- cover module with optional display

It offers easy installation and the possibility for fast exchange of the sensor unit for service purposes.

The EE23 can be employed in all common applications by choosing the appropriate housing combination.

- A and B versions are dedicated for wall or duct mounting.
- C version with the remote sensing probe has a working temperature range  $-40...120^{\circ}\text{C}$
- F wall mounting version with rear cable outlets is dedicated for clean room applications. Connection cables do not disturb the cleaning process.
- G version with optional radiation shield is dedicated for outdoor and meteorological applications.

The high quality HC series humidity sensor elements and newest microprocessor technology are the guarantee for best accuracy, excellent long term stability, small hysteresis and highest resistance to pollutants.

Easy configuration of the humidity and temperature outputs is made possible by the innovative design of the EE23 electronics. One can select between various current or voltage output signals.

Optionally the transmitters are available with passive temperature sensor elements with a free choice of the sensor type.

An optional hygrostate output for control and alarm purposes completes the wide range of offerings.

One can very easily perform a two point adjustment on site by using two push buttons and an optional display.

The three modules concept makes it also possible to perform a loop calibration according to FDA (Food and Drug Administration) recommendations.

Further options are the integrated display and cable outlets via connectors.

### Multifunctional Humidity & Temperature Transmitter



Model A + F



Model B



Model C



Model G

## Field calibration

The three modules housing design allows a fast and easy dismounting of the EE23 for field calibration. No interruption of the measurement is necessary for loop calibration which is essential for the calibration procedure recommended by FDA (Food and Drug Administration).

- ① EE23 back module mounted on the wall
- ② EE23 extension cable (can be ordered separately)
- ③ EE23 middle module mounted in the calibrator
- ④ Humidity reference system (e.g. HUMOR10)

Utilization of the extension cable enables the user to perform full loop calibration as recommended by FDA.

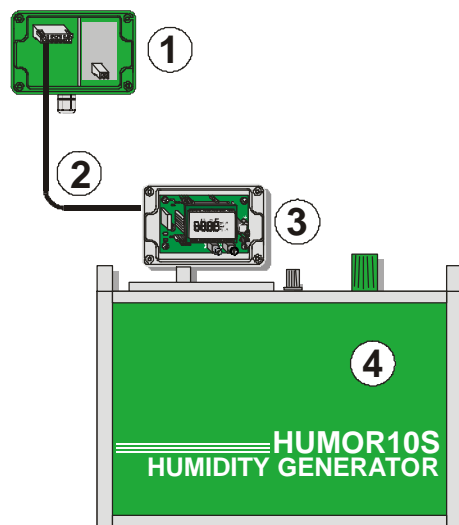

## Two Point Adjustment

With an easy routine the user can perform a fast and accurate two point adjustment.



## Display

The actual measured data can be indicated on the optional integrated display. It is possible to choose between relative humidity (RH), temperature (T) or both.



## Configuration

The configuration kit consists of the hardware interface module and the communication software. Individual adjustments of the analogue outputs, the temperature output scaling and the display mode can be set by software.



## Alarm Output

Simple control applications can be solved by the optional alarm output of the EE23. The user can set threshold and hysteresis by potentiometers.

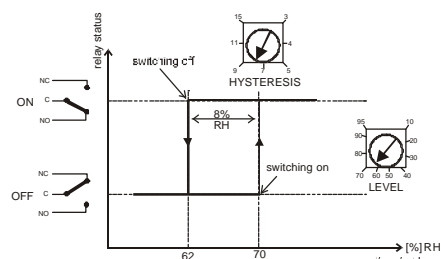

**Typical Applications**

- high end HVAC
- climate chambers
- process technology
- dryers
- meteorology
- clean rooms
- green houses
- stocks

**Features**

- temperature range -40..120degC
- very easy mounting
- fast and easy service and replacement
- on site calibration
- best accuracy over whole temperature range
- remote sensing probe up to 10 m
- alarm output

**Dimensions (mm)**

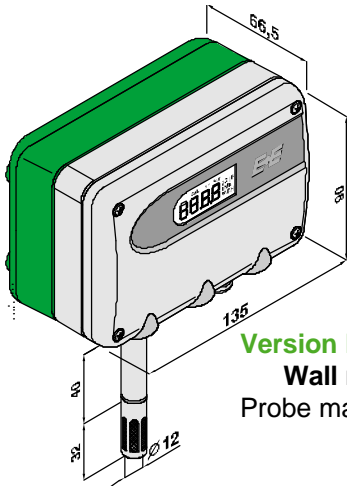

**Version EE23-xAx**  
**Wall mounting**  
 Probe material: PC

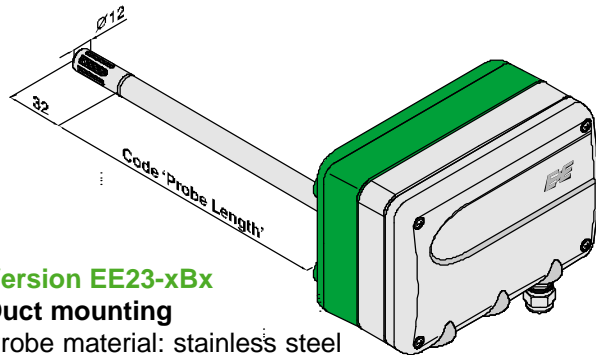

**Version EE23-xBx**  
**Duct mounting**  
 Probe material: stainless steel

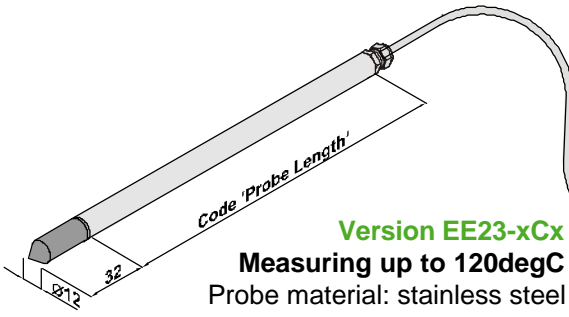

**Version EE23-xCx**  
**Measuring up to 120degC**  
 Probe material: stainless steel

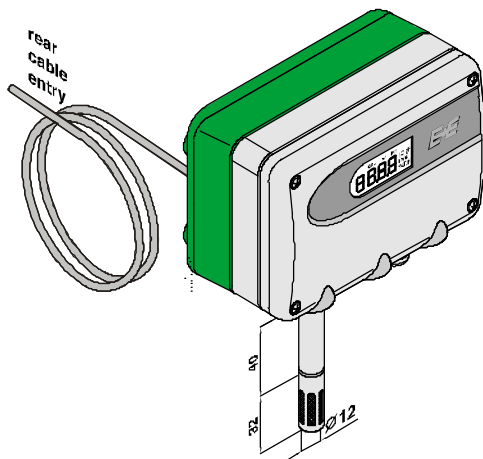

**Version EE23-xFx**  
**Wall mounting with rear cable entry**  
 Probe material: PC

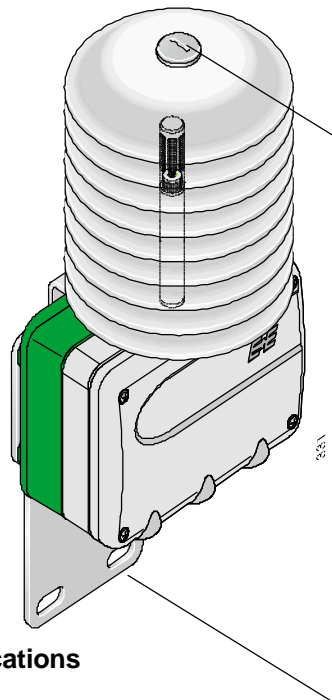

**Version EE23-xGx**  
**Meteorology applications**  
 Probe material: PC

## Technical Data EE23

### Measured quantities

#### Relative humidity

Humidity sensor <sup>1)</sup>	HC1000-200 or HC1000-200C	
Working range <sup>1)</sup>	0...100 %RH	
Accuracy incl. hysteresis and nonlinearity with		
- special calibration against certified standards	± 1 %RH (0...90 %RH)	± 2 %RH (90...100 %RH)
- standard calibration	± 2 %RH (0...90 %RH)	± 3 %RH (90...100 %RH)
Guaranteed accuracy limits - GAL 23 according to standard NFX15.113	for range 0-90 % RH :	2.35 % RH
	for range 0-100 % RH :	2.96 % RH
Temperature dependence electronics	typ. 0.06 %RH/degC	
Temperature dependence sensing probe	typ. 0.03 %RH/degC	
Response time with metal grid filter at 20 degC / t <sub>90</sub>	< 15 sec.	

#### Temperature

Temperature sensor element	Pt1000 (class A, DIN EN 60751)		
Working range sensing head	EE23-xAx -40...60 degC (-40...140 °F)	EE23-xBx -40...80 degC (-40...176 °F)	
	EE23-xCx -40...120 degC (-40...248 °F)	EE23-xFx -40...60 degC (-40...140 °F)	
	EE23-xGx -40...60 degC (-40...140 °F)		

Accuracy (typ.)

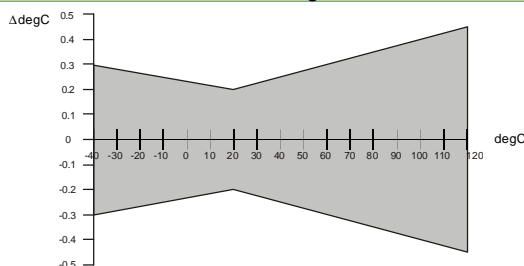

Temperature dependence of electronics	typ. 0.005 degC/degC
---------------------------------------	----------------------

### Outputs

0...100 %RH / xx...yy degC <sup>3)</sup>	0 - 5 V	-1 mA < I <sub>L</sub> < 1 mA
(temperature output scale adjustable by E+E or with configuration kit)	0 - 10 V	-1 mA < I <sub>L</sub> < 1 mA
	0 - 20mA	R <sub>L</sub> < 350 Ohm
	4 - 20 mA	R <sub>L</sub> < 350 Ohm

### General

Supply voltage		
for 0 - 5 V outputs	10.5 VDC - 28 VDC	or 12 VAC - 28 VAC
for 0 - 10 V, 0 - 20 mA and 4-20 mA outputs	15.0 VDC - 28 VDC	or 15 VAC - 28 VAC
Current consumption for voltage output		
for DC supply ≤ 25 mA	with alarm module: for DC supply	≤ 35 mA
for AC supply ≤ 35 mA eff.	for AC supply	≤ 60 mA <sub>eff</sub>
Current consumption for current output		
for DC supply ≤ 50 mA	with alarm module: for DC supply	≤ 60 mA
for AC supply ≤ 90 mA eff.	for AC supply	≤ 110 mA <sub>eff</sub>
Housing / protection class	PC / IP65	
Cable gland <sup>2)</sup>	M16x1.5	
Electrical connection <sup>2)</sup>	screw terminals max. 1.5 mm <sup>2</sup>	
Sensor protection	sintered stainless steel filter, PTFE or metal grid filter	
Working temperature range of electronics	-40...+60 degC (-40...140 °F)	
Working temperature range with display	-30...+60 degC (-22...140 °F)	
Storage temperature range	-30...+60 degC (-22...140 °F)	

<sup>1)</sup> Refer to the working range of the humidity sensor!

<sup>2)</sup> Connection plugs refer to 'Accessories'!

<sup>3)</sup> Refer to ordering code

CE compatibility according

EN61000-6-2  
 EN50081-1 EN61010-1

**Alarm Module - optional**

Output	SPDT-Switch up to 250VAC/8A or 28VDC/8A	
	threshold	hysteresis
Setting range	10...95 %RH	3...15%RH
Setting accuracy	± 3 %RH	

**Humidity Sensor - Working Range**

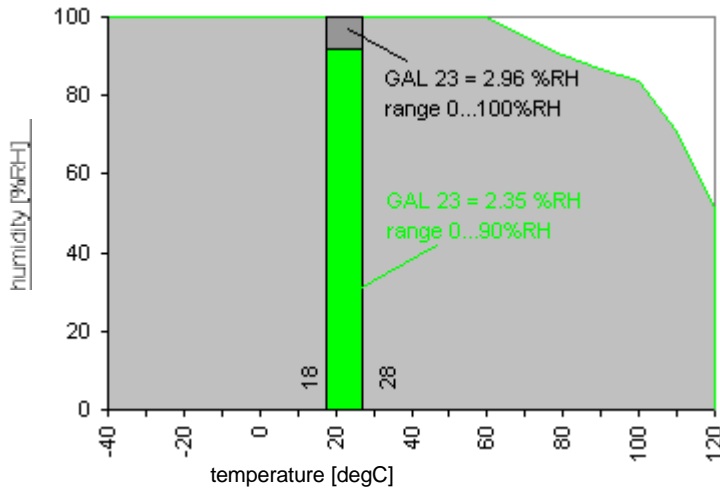

The working range of the humidity sensor element is shown in terms of humidity / temperature limits.

Although the sensors would not deteriorate beyond the limits, their performance can only be specified within the limits of the working range.

**Humidity Sensor with Coating**

For very dirty and corrosive industrial environment the EE23 series can be equipped with the humidity sensor element HC1000-200C. Details upon request.

**High Humidity Calibration**

For applications with a steady climate of > 90%RH we recommend a special high humidity calibration .

**Connecting Diagram**

**output and supply**

with active temperature output

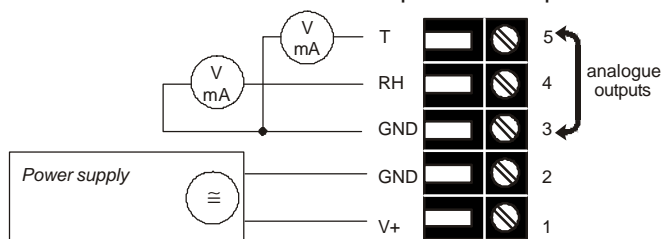

**alarm output**

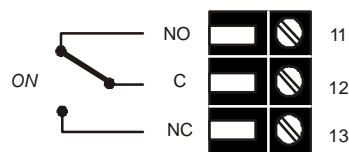

with passive temperature output

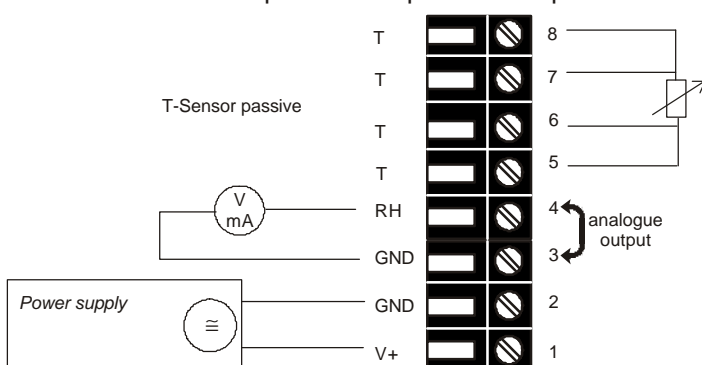

## Ordering Guide

### Order Code - Hardware Settings

MODEL	HOUSING TYPE	FILTER	CABLE LENGTH		PROBE LENGTH	
			(only Model C)		(only Model B + C)	
humidity + temperature (FT)	wall mounting (A)	stainless steel (3)	2 m (02)		50 mm (2)	
humidity (F)	duct mounting (B)	PTFE (5)	5 m (05)		200 mm (5)	
humidity + Ptxxx passive (FPtxxx) <sup>1)</sup>	remote probe up to 120 degC (C)	metal grid (6)	10 m (10)		400 mm (6)	
	wall mounting - rear cable entry (F)					
	wall mounting - for meteorology (G)					
<b>EE23-</b>						

### Order Code - Hardware Settings

DISPLAY	ALARM OUTPUT	CONNECTOR	HUMIDITY SENSOR	CALIBRATION
(refer to software code)				
no display (no code)	no alarm output (no code)	standard cable 1 gland M16x1,5 (no code)	HC1000-200 (no code)	no special calibration (no code)
display (D03)	alarm output (SW)	2 glands M16x1,5 (C11)	HC1000-200C (HC01)	high humidity calibration (CA1)
		one plug for supply and outputs (C03)		
		two plugs for supply + outputs and alarm output (C09)		

### Code for - Software Settings

OUTPUT	UNITS	RANGE FOR TEMPERATURE OUTPUT SCALING		DISPLAY MODE
0 - 5 V (2)	°C (no code)	-40...60 degC (-40...140 °F) (T02)	-40...120 degC (-40...248 °F) (T12)	humidity and temperature alternating (TH)
0 - 10 V (3)	°F (E01)	-10...50 degC (14...122 °F) (T03)	+20...120 degC (68...248 °F) (T15)	
0 - 20 mA (5)		0...50 degC (32...122 °F) (T04)	-30...60 degC (-22...140 °F) (T20)	humidity (RH)
4 - 20 mA (6)		0...100 degC (32...212 °F) (T05)	0...80 degC (32...176 °F) (T21)	
		0...60 degC (32...140 °F) (T07)	-40...80 degC (-40...176 °F) (T22)	temperature (TE)
		-30...70 degC (-22...158 °F) (T08)	-20...80 degC (-4...176 °F) (T24)	
		-30...120 degC (-22...248 °F) (T09)	-20...60 degC (-4...160 °F) (T25)	
		-20...120 degC (-4...248 °F) (T10)	-30...50 degC (-22...122 °F) (T45)	
		-10...70 degC (14...158 °F) (T11)	-20...50 degC (-4...122 °F) (T48)	

1) only for housing type A, F and G

## Accessories

(please refer to data sheet 'Accessories')

- filter caps
- configuration kit
- radiation shield
- cable connectors
- external power supply unit
- display
- mounting flange
- bracket for installation onto mounting rails
- replacement sensors
- drip water protection
- calibration set

## Order example

### EE23-FTC6025D03/6-T12-TH

model:	humidity and temperature
type of housing:	separated sensor probe
filter:	metal grid
cable length:	2 m
probe length:	200 mm
display:	yes
output:	4 - 20 mA
units of measurements:	metric
temperature scaling:	-40...+120°C
display mode:	humidity/temperature alternating